

AUSTER

leading innovation

GS650 WOOD CHIPPER



Weifang Austter Industry & Trade Co.,Ltd.
East Mountain Industrial Park, 262100
ShuangFeng Avenue, AnQiu
Weifang City, China
Tel: +86 155 0536 8258
E-mail: info@austter.com
www.austter.com





MOTOR/ENGINE

- Petrol
 - Ducar DG196 6.5hp
 - Loncin G200F 6.5hp
 - B&S XR950 6.5hp
 - Honda GX200 6.5hp

CHIP SYSTEM

- Chip type: Rotor type
- Chip capacity: Fresh 80mm, Dry 55mm
- Working RPM: 2400 rpm
- Blade number: 2 x drum blade, 1 x stationary blade
- Blade material: SKH-51



FRAME

- Axis: 30mm/Steel rod dia. 30mm
- Wheel: 4.10/3.50-4 tubeless tire

PACKING

- Packing method: Plywood case
- Packing size: 880*565*850mm
- Gross weight: 100kg
- 20GP load quantity: 48 sets
- 40HQ load quantity: 156 sets

SAFETY

- Emergency stop: MZ-8112 emergency switch from GoerTec

Dimensions / dimensiones

	mm	in
Ⓐ	1800	70.87
Ⓑ	1250	49.21
Ⓒ	625	24.61

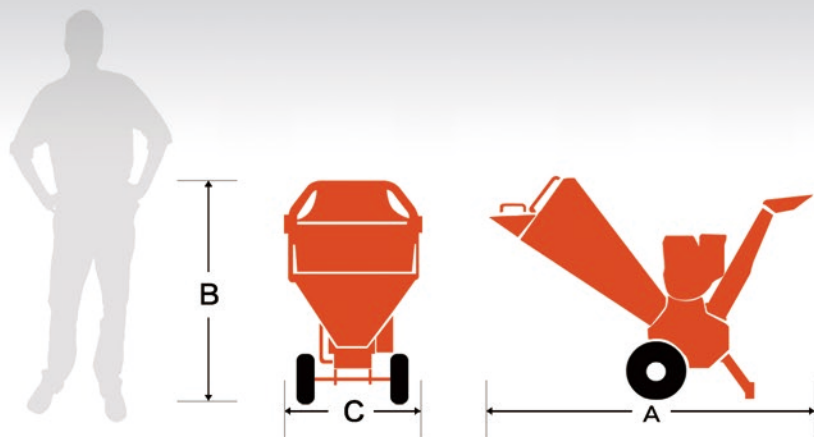

The Austter GS650 is a self-feeding gasoline engine powered wood chipper that features a 6" x 5" infeed opening and can handle material up to 3" in diameter. Weighing in at 187 pounds this drum style chipper is equipped with a gasoline engine that boasts 6.5 HP and 9.50 ft./lbs. of torque. The material is fed into a sloped infeed bin and fed into the 9" diameter 30 lb. chipper drum that acts as a power feed assist system pulling the branches in at up to 35' per/min. Although the chipper weighs almost 200 pounds it is perfectly balanced and can be easily moved around the work site.



TUV-SUD CERTIFICATE

- CE test no. 4840317044500
- EMC test no. 4840317241200



Product Service

Attestation of Conformity

No. E8A 17 07 99731 002

Holder of Certificate: Weifang Austter Industry and Trade Co., Ltd.
Heyatou Industry Area
Weicheng District
261011 Weifang City, Shandong Province
PEOPLE'S REPUBLIC OF CHINA

Name of Object: Disintegrator for garden waste
Wood chipper

Model(s): GS650, GS1500

Description of Object:
Rated speed: 3600/min
Rated power: 4100W(GS650), 9000W(GS1500)
Rated displacement: 420cc(GS1500), 196cc(GS650)

Tested according to: EN ISO 14982:2009

This Attestation of Conformity is issued on a voluntary basis according to the Directive 2014/30/EU relating to electromagnetic compatibility. It confirms that the listed apparatus complies with all essential requirements of the directive and is based on the technical specifications applicable at the time of issuance. It refers only to the particular sample submitted for testing and certification. See also notes overleaf.

Test report no.: 4840317241200



Date, 2017-07-27

Xiao Liu
(Xiao Liu)

CE After preparation of the necessary technical documentation as well as the EU declaration of conformity the required CE marking can be affixed on the product. That declaration of conformity is issued under the sole responsibility of the manufacturer. Other relevant EU-directives have to be observed.

Page 1 of 1

TÜV SÜD Product Service GmbH · Zertifizierstelle · Ridlerstraße 65 · 80339 München · Germany

TUV®



Product Service

Attestation of Conformity

No. M8A 17 06 99731 001

Holder of Certificate: Weifang Austter Industry and Trade Co., Ltd.
Heyatou Industry Area
Weicheng District
261011 Weifang City, Shandong Province
PEOPLE'S REPUBLIC OF CHINA

Product: Disintegrator for garden waste
Wood chipper

Model(s): GS650, GS1500

Parameters:
Rated engine power: 4,1kW/3600min(GS650)
9,0kW/3600min(GS1500)
Engine displacement: 196cm³(GS650)
420cm³(GS1500)
Blade Length: 150mm(GS650), 300mm(GS1500)

Tested according to: EN ISO 12100:2010

This Attestation of Conformity is issued on a voluntary basis according to Council Directive 2006/42/EC relating to machinery. It confirms that the listed equipment (not Annex IV equipment) complies with the principal protection requirements of the directive. It refers only to the sample submitted to TÜV SÜD Product Service GmbH for testing and certification. See also notes overleaf.

Test report no.: 4840317044500



Date, 2017-07-12

Xianfeng Ni
(Xianfeng Ni)

CE After preparation of the necessary technical documentation as well as the EC declaration of conformity the required CE marking can be affixed on the product. Other relevant directives have to be observed.

Page 1 of 1

TÜV SÜD Product Service GmbH · Zertifizierstelle · Ridlerstraße 65 · 80339 München · Germany

TUV®

AUSTER

